



The voltage of the frequency converter is dangerous whenever the equipment is connected to mains. Incorrect installation of the motor or the frequency converter may cause damage to the equipment, serious personal injury or death. Consequently, the instructions in this manual, as well as national and local rules and safety regulations, must be complied with.

### ■ Safety regulations

1. The frequency converter must be disconnected from mains if repair work is to be carried out. Check that the mains supply has been disconnected and that the necessary time has passed before removing motor and mains plugs.
2. The [STOP/RESET] key on the control panel of the frequency converter does not disconnect the equipment from mains and is thus not to be used as a safety switch.
3. Correct protective earthing of the equipment must be established, the user must be protected against supply voltage, and the motor must be protected against overload in accordance with applicable national and local regulations.
4. The earth leakage currents are higher than 3.5 mA.
5. Protection against motor overload is not included in the factory setting. If this function is desired, set parameter 128 to data value *ETR trip* or data value *ETR warning*.  
Note: The function is initialised at 1.16 x rated motor current and rated motor frequency. For the North American market: The ETR functions provide class 20 motor overload protection in accordance with NEC.
6. Do not remove the plugs for the motor and main supply while the frequency converter is connected to mains. Check that the mains supply has been disconnected and that the necessary time has expired before removing motor and mains plugs.
7. Please note that the frequency converter has more voltage inputs than L1, L2 and L3, when loadsharing (linking of DC intermediate circuit) and external 24 V DC have been installed. Check that all voltage inputs have been disconnected and that the necessary time has passed before repair work is commenced.

### ■ Warning against unintended start

1. The motor can be brought to a stop by means of digital commands, bus commands, references or a local stop, while the frequency converter is connected to mains. If personal safety considerations make it necessary to ensure that no unintended start occurs, these stop functions are not sufficient.
2. While parameters are being changed, the motor may start. Consequently, the stop key [STOP/RESET] must always be activated, following which data can be modified.
3. A motor that has been stopped may start if faults occur in the electronics of the frequency converter, or if a temporary overload or a fault in the supply mains or the motor connection ceases.

### ■ Quick Setup

#### ■ Introduction to Quick Setup

This Quick Setup will guide you through EMC correct installation of the frequency converter by connecting power, motor and control wiring (fig. 1). Start/stop of motor is to be done with the switch.

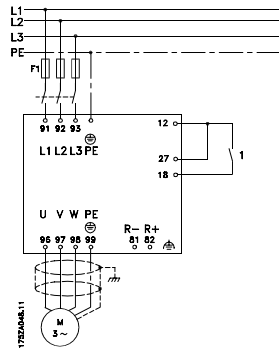

Fig. 1

### ■ 1. Mechanical Installation

AKD 5000 frequency converters allow side-by-side mounting. The necessary cooling demands a free air passage of 10 cm above and below the frequency converter (5016-5062 380-500 V and 5008-5027 200-240 V must have 20 cm).

Drill all holes by using the measurements stated in the table. Please note the difference in unit voltage. Place the frequency converter on the wall. Tighten up all four screws.

All the below listed measurements are in mm

AKD type	A	B	C	a	b
Compact IP 20, 200-240 V (Fig. 4)					
5001 - 5003	395	220	160	384	200
5004 - 5006	395	220	200	384	200
5008	560	242	260	540	200
5011 - 5016	700	242	260	680	200
5022 - 5027	800	308	296	780	270
Compact IP 20, 380-500 V (Fig. 4)					
5001 - 5005	395	220	160	384	200
5006 - 5011	395	220	200	384	200
5016 - 5022	560	242	260	540	200
5027 - 5032	700	242	260	680	200
Compact IP 54, 200-240 V (Fig. 3)					
5001 - 5003	460	282	195	260	258
5004 - 5006	530	282	195	330	258
5008 - 5011	810	350	280	560	326
5016 - 5027	940	400	280	690	375
Compact IP 54, 380-500 V (Fig. 3)					
5001 - 5005	460	282	195	260	258
5006 - 5011	530	282	195	330	258
5016 - 5027	810	350	280	560	326
5032 - 5062	940	400	280	690	375
5042 - 5062	800	308	296	780	270

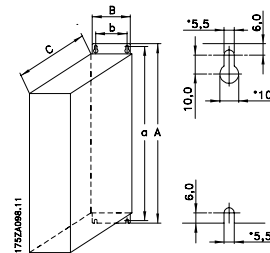

Fig. 2

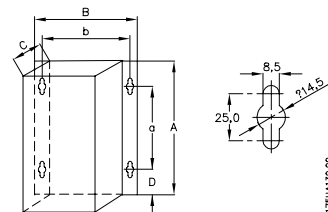

Fig. 3

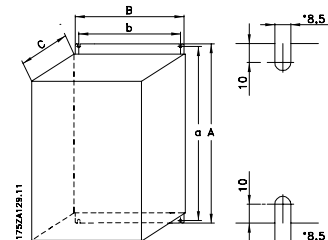
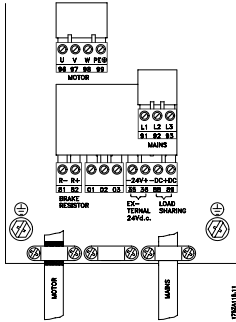

Fig. 4

### ■ 2. Electrical Installation, power

NOTE: The terminals are detachable on AKD 5001-5006, 200-240 V and AKD 5001-5011, 380-500 V  
 Connect the mains supply to the mains terminals L1, L2, L3 of the frequency converter and to the earth connection (fig. 5-8). Cable relief fitting is placed on the wall for Bookstyle units. Mount screened motor cable to the motor terminals U, V, W, PE of the frequency converter. Make sure, the screen is connected electrically to the drive.



**Fig. 6**  
**Compact IP 20 and IP 54**  
 5001 - 5011 380 - 500 V  
 5001 - 5006 200 - 240 V

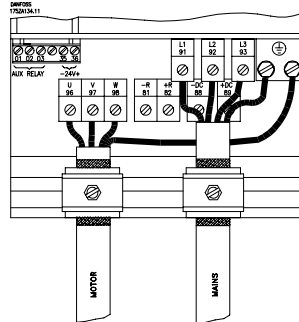

**Fig. 7**  
**Compact IP 20**  
 5016 - 5062 380 - 500 V  
 5008 - 5027 200 - 240 V

Quick Setup

### ■ Ordering form AKD 5000 Series - Typecode

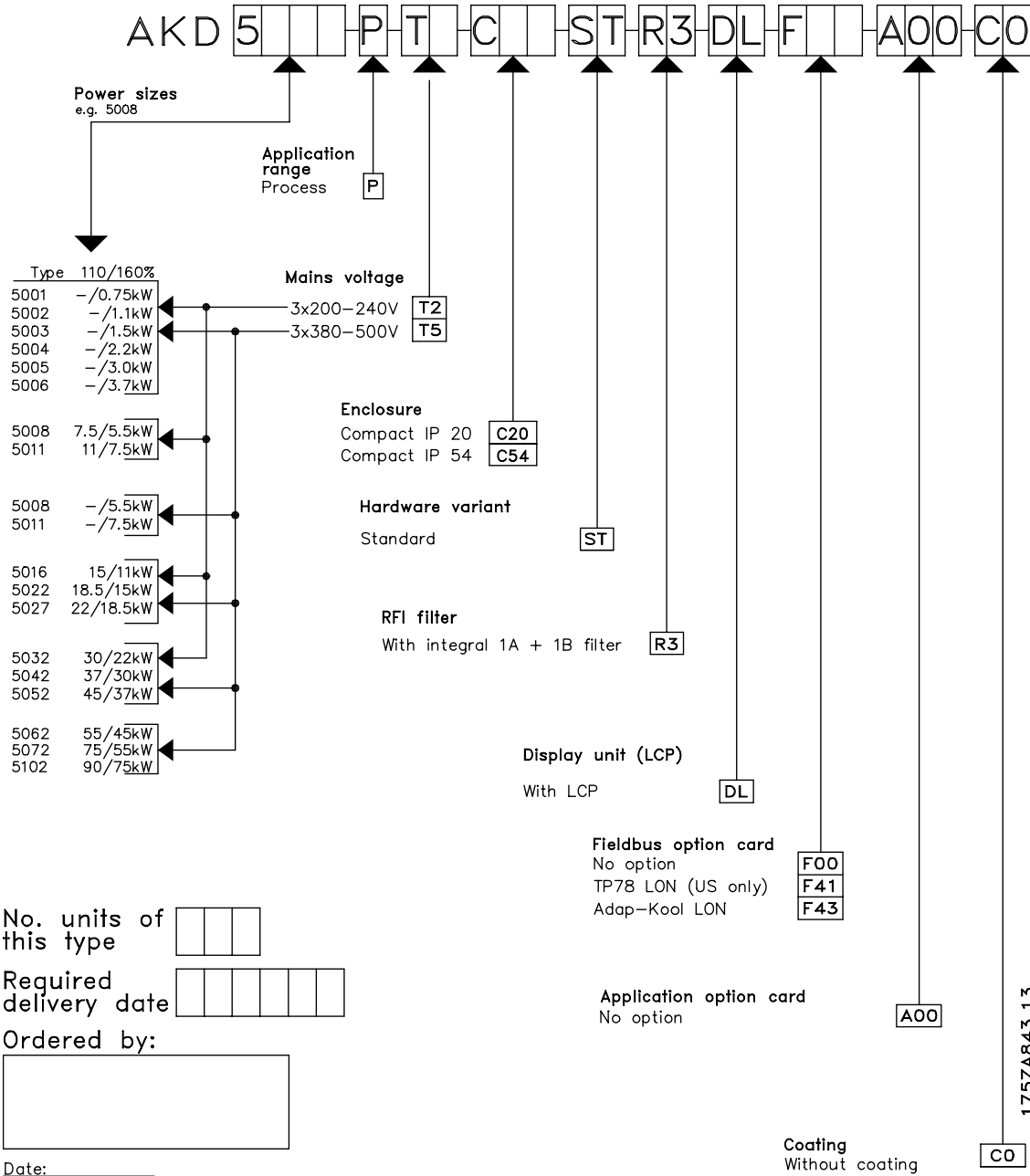

Introduction

**■ General technical data**

Mains supply (L1, L2, L3):

---

Supply voltage 200-240 V units .....	3 x 200/208/220/230/240 V ±10%
Supply voltage 380-500 V units .....	3 x 380/400/415/440/460/500 V ±10%
Supply frequency .....	48/62 Hz +/- 1%
AKD 5001-5011, 380-500 V and AKD 5001-5006, 200-240 V .....	±2.0% of rated supply voltage
AKD 5016-5062, 380-500 V and AKD 5008-5027, 200-240 V .....	±1.5% of rated supply voltage
True Power factor ( $\lambda$ ) .....	0.90 nominal at rated load
Displacement Power Factor ( $\cos \phi$ ) .....	near unity (>0.98)
No. of switchings on supply input L1, L2, L3 .....	approx. 1 time/min.

*See the section on special conditions in the Design Guide*

AKD output data (U, V, W):

---

Output voltage .....	0-100% of supply voltage
Output frequency .....	0-132 Hz, 0-1000 Hz
Rated motor voltage, 200-240 V units .....	200/208/220/230/240 V
Rated motor voltage, 380-500 V units .....	380/400/415/440/460/480/500 V
Rated motor frequency .....	50/60 Hz
Switching on output .....	Unlimited
Ramp times .....	0.05-3600 sec.

Torque characteristics:

---

Starting torque, AKD 5001-5027, 200-240 V and AKD 5001-5062, 380-500 V .....	160% for 1 min.
Starting torque .....	180% for 0.5 sec.
Acceleration torque .....	100%
Overload torque, AKD 5001-5027, 200-240 V and AKD 5001-5062, 380-500 V .....	160%
Arresting torque at 0 rpm (closed loop) .....	100%

*The torque characteristics given are for the frequency converter at the high overload torque level (160%). At the normal overload torque (110%), the values are lower.*

Control card, digital inputs:

---

Number of programmable digital inputs .....	8
Terminal nos. ....	16, 17, 18, 19, 27, 29, 32, 33
Voltage level .....	0-24 V DC (PNP positive logics)
Voltage level, logical '0' .....	< 5 V DC
Voltage level, logical '1' .....	>10 V DC
Maximum voltage on input .....	28 V DC
Input resistance, $R_i$ .....	2 k $\Omega$
Scanning time per input .....	3 msec.

*Reliable galvanic isolation: All digital inputs are galvanically isolated from the supply voltage (PELV).  
In addition, the digital inputs can be isolated from the other terminals on the control card by connecting an external 24 V DC supply and opening switch 4.*

Control card, analogue inputs:

---

No. of programmable analogue voltage inputs/thermistor inputs .....	2
Terminal nos. ....	53, 54
Voltage level .....	0 - ±10 V DC (scalable)
Input resistance, $R_i$ .....	10 k $\Omega$
No. of programmable analogue current inputs .....	1
Terminal no. ....	60
Current range .....	0/4 - ±20 mA (scalable)
Input resistance, $R_i$ .....	200 $\Omega$
Resolution .....	10 bit + sign

---

Accuracy on input ..... Max. error 1% of full scale  
 Scanning time per input ..... 3 msec.  
 Terminal no. ground ..... 55  
*Reliable galvanic isolation: All analogue inputs are galvanically isolated from the supply voltage (PELV) as well as other inputs and outputs.*

Control card, pulse/encoder input:

No. of programmable pulse/encoder inputs ..... 4  
 Terminal nos. .... 17, 29, 32, 33  
 Max. frequency on terminal 17 ..... 5 kHz  
 Max. frequency on terminals 29, 32, 33 ..... 20 kHz (PNP open collector)  
 Max. frequency on terminals 29, 32, 33 ..... 65 kHz (Push-pull)  
 Voltage level ..... 0-24 V DC (PNP positive logics)  
 Voltage level, logical '0' ..... < 5 V DC  
 Voltage level, logical '1' ..... >10 V DC  
 Maximum voltage on input ..... 28 V DC  
 Input resistance,  $R_i$  ..... 2 k $\Omega$   
 Scanning time per input ..... 3 msec.  
 Resolution ..... 10 bit + sign  
 Accuracy (100-1 kHz), terminals 17, 29, 33 ..... Max. error: 0.5% of full scale  
 Accuracy (1-5 kHz), terminal 17 ..... Max. error: 0.1% of full scale  
 Accuracy (1-65 kHz), terminals 29, 33 ..... Max. error: 0.1% of full scale  
*Reliable galvanic isolation: All pulse/encoder inputs are galvanically isolated from the supply voltage (PELV). In addition, pulse and encoder inputs can be isolated from the other terminals on the control card by connecting an external 24 V DC supply and opening switch 4.*  
*See section on Control cables.*

Control card, digital/pulse and analogue outputs:

No. of programmable digital and analogue outputs ..... 2  
 Terminal nos. .... 42, 45  
 Voltage level at digital/pulse output ..... 0 - 24 V DC  
 Minimum load to ground (terminal 39) at digital/pulse output ..... 600  $\Omega$   
 Frequency ranges (digital output used as pulse output) ..... 0-32 kHz  
 Current range at analogue output ..... 0/4 - 20 mA  
 Maximum load to ground (terminal 39) at analogue output ..... 500  $\Omega$   
 Accuracy of analogue output ..... Max. error: 1.5% of full scale  
 Resolution on analogue output. .... 8 bit  
*Reliable galvanic isolation: All digital and analogue outputs are galvanically isolated from the supply voltage (PELV), as well as other inputs and outputs.*

Control card, 24 V DC supply:

Terminal nos. .... 12, 13  
 Max. load (short-circuit protection) ..... 200 mA  
 Terminal nos. ground ..... 20, 39  
*Reliable galvanic isolation: The 24 V DC supply is galvanically isolated from the supply voltage (PELV), but has the same potential as the analogue outputs.*

Control card, RS 485 serial communication:

Terminal nos. .... 68 (TX+, RX+), 69 (TX-, RX-)  
*Reliable galvanic isolation: Full galvanic isolation.*

Technical data

### Relay outputs:<sup>1)</sup>

No. of programmable relay outputs .....	2
Terminal nos., control card (resistive load only) .....	4-5 (make)
Max. terminal load (AC1) on 4-5, control card .....	50 V AC, 1 A, 50 VA
Max. terminal load (DC1 (IEC 947)) on 4-5, control card .....	25 V DC, 2 A / 50 V DC, 1 A, 50 W
Max. terminal load (DC1) on 4-5, control card for UL/cUL applications .....	30 V AC, 1 A / 42.5 V DC, 1 A
Terminal nos., power card (resistive and inductive load) .....	1-3 (break), 1-2 (make)
Max. terminal load (AC1) on 1-3, 1-2, power card .....	250 V AC, 2 A, 500 VA
Max. terminal load (DC1 (IEC 947)) on 1-3, 1-2, power card .....	25 V DC, 2 A / 50 V DC, 1A, 50 W
Min. terminal load (AC/DC) on 1-3, 1-2, power card .....	24 V DC, 10 mA / 24 V AC, 100 mA

1) Rated values for up to 300,000 operations.

At inductive loads the number of operations are reduced by 50%, alternatively the current can be reduced by 50%, thus the 300,000 operations are maintained.

### External 24 Volt DC supply:

Terminal nos. ....	35, 36
Voltage range .....	24 V DC $\pm$ 15% (max. 37 V DC for 10 sec.)
Max. voltage ripple .....	2 V DC
Power consumption .....	15 W - 50 W (50 W for start-up, 20 msec.)
Min. pre-fuse .....	6 Amp

*Reliable galvanic isolation: Full galvanic isolation if the external 24 V DC supply is also of the PELV type.*

### Cable lengths, cross-sections and connectors:

Max. motor cable length, screened cable .....	150 m
Max. motor cable length, unscreened cable .....	300 m
Max. motor cable length, screened cable AKD 5011 380-500 V .....	100 m
Max. brake cable length, screened cable .....	20 m
Max. loadsharing cable length, screened cable .....	25 m from frequency converter to DC bar.
<i>Max. cable cross-section for motor, brake and loadsharing, see next section</i>	
Max. cable cross-section for 24 V external DC supply .....	4.0 mm <sup>2</sup> /10 AWG
Max. cross-section for control cables .....	1.5 mm <sup>2</sup> /16 AWG
Max. cross-section for serial communication .....	1.5 mm <sup>2</sup> /16 AWG
<i>If UL/cUL is to be complied with, cable with temperature class 60/75°C must be used</i>	
<i>(AKD 5001-5062 380-500 V and AKD 5001-5027 200-240 V).</i>	

### Accuracy of display readout (parameters 009-012):

Motor current [6] 0-140% load .....	Max. error: $\pm$ 2.0% of rated output current
Torque % [7], -100 - 140% load .....	Max. error: $\pm$ 5% of rated motor size
Output [8], power HP [9], 0-90% load .....	Max. error: $\pm$ 5% of rated output

### Control characteristics:

Frequency range .....	0 - 1000 Hz
Resolution on output frequency .....	±0.003 Hz
System response time .....	3 msec.
Speed, control range (open loop) .....	1:100 of synchro. speed
Speed, control range (closed loop) .....	1:1000 of synchro. speed
Speed, accuracy (open loop) .....	< 1500 rpm: max. error ± 7.5 rpm
.....	>1500 rpm: max. error of 0.5% of actual speed
Speed, accuracy (closed loop) .....	< 1500 rpm: max. error ± 1.5 rpm
.....	>1500 rpm: max. error of 0.1% of actual speed
Torque control accuracy (open loop) .....	0- 150 rpm: max. error ±20% of rated torque
.....	150-1500 rpm: max. error ±10% of rated torque
.....	>1500 rpm: max. error ±20% of rated torque
Torque control accuracy (speed feedback) .....	Max. error ±5% of rated torque

*All control characteristics are based on a 4-pole asynchronous motor*

### Externals:

Enclosure .....	IP 20, IP 54
Vibration test .....	0.7 g RMS 18-1000 Hz random. 3 directions for 2 hours (IEC 68-2-34/35/36)
Max. relative humidity .....	93 % (IEC 68-2-3) for storage/transport
Max. relative humidity .....	95 % non condensing (IEC 721-3-3; class 3K3) for operation
Aggressive environment (IEC 721 - 3 - 3) .....	Uncoated class 3C2
Aggressive environment (IEC 721 - 3 - 3) .....	Coated class 3C3
Ambient temperature IP 20 (high overload torque 160%) .....	Max. 45°C (24-hour average max. 40°C)
Ambient temperature IP 20 (normal overload torque 110%) .....	Max. 40°C (24-hour average max. 35°C)
Ambient temperature IP 54 (high overload torque 160%) .....	Max. 40°C (24-hour average max. 35°C)
Ambient temperature IP 54 (normal overload torque 110%) .....	Max. 40°C (24-hour average max. 35°C)
Ambient temperature IP 20/54 AKD 5011 500 V .....	Max. 40°C (24-hour average max. 35°C)

*Derating for high ambient temperature, see the Design Guide*

Min. ambient temperature in full operation .....	0°C
Min. ambient temperature at reduced performance .....	-10°C
Temperature during storage/transport .....	-25 - +65/70°C
Max. altitude above sea level .....	1000 m

*Derating for high air altitude, see the Design Guide*

EMC standards applied, Emission .....	EN 50081-1/2, EN 61800-3, EN 55011
EMC standards applied, Immunity .....	EN 61000-6-2, EN 61000-4-2, EN 61000-4-3, EN 61000-4-4
EN 61000-4-5, EN 61000-4-6, VDE 0160/1990.12	

*See section on special conditions in the Design Guide.*

### AKD 5000 Series protection:

- Electronic motor thermal protection against overload.
- Temperature monitoring of heat-sink ensures that the frequency converter cuts out if the temperature reaches 90°C for IP 20. For IP 54, the cut-out temperature is 80°C. An overtemperature can only be reset when the temperature of the heat-sink has fallen below 60°C.
- The frequency converter is protected against short-circuiting on motor terminals U, V, W.
- The frequency converter is protected against earth fault on motor terminals U, V, W.
- Monitoring of the intermediate circuit voltage ensures that the frequency converter cuts out if the intermediate circuit voltage gets too high or too low.
- If a motor phase is missing, the frequency converter cuts out.
- If there is a mains fault, the frequency converter is able to carry out a controlled deceleration.
- If a mains phase is missing, the frequency converter will cut out when a load is placed on the motor.

### Compact, Mains supply 3 x 380 - 500 V

According to international requirements		AKD type	5032	5042	5052	5062	5072	5102
<b>Normal overload torque (110 %):</b>								
Output current	$I_N$ [A] (380-440 V)		61	73	90	106	147	177
	$I_{MAX}$ (60 s) [A] (380-440 V)		67.1	80.3	99	117	162	195
	$I_N$ [A] (441-500 V)		54	65	78	106	130	160
	$I_{MAX}$ (60 s) [A] (441-500 V)		59.4	71.5	85.8	117	143	176
Output	$S_N$ [kVA] (380-440 V)		46.5	55.6	68.6	80.8	102	123
	$S_N$ [kVA] (441-500 V)		46.8	56.3	67.5	91.8	113	139
Typical shaft output	$P_N$ [kW] (500 V)		30	37	45	55	75	90
Typical shaft output	$P_N$ [HP] (500 V)		40	50	60	75	90	110
<b>High overload torque (160 %):</b>								
Output current	$I_N$ [A] (380-440 V)		44	61	73	90	106	147
	$I_{MAX}$ (60 s) [A] (380-440 V)		70.7	97.6	116.8	135	159	221
	$I_N$ [A] (441-500 V)		41.4	54	65	80	106	130
	$I_{MAX}$ (60 s) [A] (441-500 V)		66.2	86	104	120	159	195
Output	$S_N$ [kVA] (380-440 V)		33.5	46.5	55.6	68.6	73.0	102
	$S_N$ [kVA] (441-500 V)		35.9	46.8	56.3	69.3	92.0	113
Typical shaft output	$P_N$ [kW] (500 V)		22	30	37	45	75	90
Typical shaft output	$P_N$ [HP] (500 V)		30	40	50	75	100	120
Max. cable cross-section to motor,		IP54	35/2	35/2	50/0	50/0	150/300	150/300
brake and loadsharing [mm <sup>2</sup> ]/[AWG] <sup>2)5)</sup>		IP20	35/2	35/2	50/0	50/0	120/250	120/250
Min. cable cross-section to motor,								
brake and loadsharing [mm <sup>2</sup> ]/[AWG]			10/8	10/8	16/6	16/6	25/4	25/4
Rated input current	$I_{L,N}$ [A] (380 V)		60	72	89	104	145	174
	$I_{L,N}$ [A] (460 V)		53	64	77	104	128	158
Max. cable cross-section		IP54	35/2	35/2	50/0	50/0	150/300	150/300
power[mm <sup>2</sup> ]/[AWG] <sup>2) 5)</sup>		IP20	35/2	35/2	50/0	50/0	120/250	120/250
Max. pre-fuses	[-]/UL <sup>1)</sup> [A]		80/80	100/100	125/125	160/150	225/225	250/250
Pre-fuse SMPS	[-]/UL <sup>6)</sup> [A]				4.0/4.0			
Efficiency					0.97			
Weight IP 20 EB	[kg]		28	41	42	43	54	54
Weight IP 54	[kg]		54	56	56	60	77	77
Power loss at max. load.								
- high overload torque	[W]		768	1065	1275	1571	1122	1467
(160 %)								
- normal overload	[W]		1065	1275	1571	1851	1322	1766
torque (110 %)								
Enclosure			IP 20/IP54					

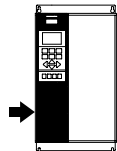
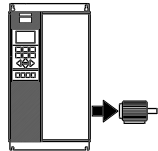

1. For type of fuse see section *Fuses*.
2. American Wire Gauge.
3. Measured using 30 m screened motor cables at rated load and rated frequency.
4. Min. cable cross-section is the smallest cable cross-section allowed to be fitted on the terminals to comply with IP 20. Always comply with national and local regulations on min. cable cross-section.
5. Aluminium cables with cross-section above 35 mm<sup>2</sup> must be connected by use of a Al-Cu connector.
6. If UL/cUL is to be complied with, Ferraz shawmut type FA Y85443, Danfoss ordering no. 612Z1182 must be used.

**■ Fuses**
**UL compliance**

To comply with UL/cUL approvals, pre-fuses according to the table below must be used.

**200-240 V**

AKD	Bussmann	SIBA	Littel fuse	Ferraz-Shawmut
5001	KTN-R10	5017906-010	KLN-R10	ATM-R10 or A2K-10R
5002	KTN-R10	5017906-010	KLN-R10	ATM-R10 or A2K-10R
5003	KTN-R25	5017906-016	KLN-R15	ATM-R15 or A2K-15R
5004	KTN-R20	5017906-020	KLN-R20	ATM-R20 or A2K-20R
5005	KTN-R25	5017906-025	KLN-R25	ATM-R25 or A2K-25R
5006	KTN-R30	5012406-032	KLN-R30	ATM-R30 or A2K-30R
5008	KTN-R50	5014006-050	KLN-R50	A2K-50R
5011	KTN-R60	5014006-063	KLN-R60	A2K-60R
5016	KTN-R85	5014006-080	KLN-R80	A2K-80R
5022	KTN-R125	2028220-125	KLN-R125	A2K-125R
5027	KTN-R125	2028220-125	KLN-R125	A2K-125R
5032	KTN-R150	2028220-160	L25S-150	A25X-150
5042	KTN-R200	2028220-200	L25S-200	A25X-200
5052	KTN-R250	2028220-250	L25S-250	A25X-250

**380-500 V**

	Bussmann	SIBA	Littel fuse	Ferraz-Shawmut
5001	KTS-R6	5017906-006	KLS-R6	ATM-R6 or A6K-6R
5002	KTS-R6	5017906-006	KLS-R6	ATM-R6 or A6K-6R
5003	KTS-R10	5017906-010	KLS-R10	ATM-R10 or A6K-10R
5004	KTS-R10	5017906-010	KLS-R10	ATM-R10 or A6K-10R
5005	KTS-R15	5017906-016	KLS-R16	ATM-R16 or A6K-16R
5006	KTS-R20	5017906-020	KLS-R20	ATM-R20 or A6K-20R
5008	KTS-R25	5017906-025	KLS-R25	ATM-R25 or A6K-25R
5011	KTS-R30	5012406-032	KLS-R30	A6K-30R
5016	KTS-R40	5012406-040	KLS-R40	A6K-40R
5022	KTS-R50	5014006-050	KLS-R50	A6K-50R
5027	KTS-R60	5014006-063	KLS-R60	A6K-60R
5032	KTS-R80	2028220-100	KLS-R80	A6K-180R
5042	KTS-R100	2028220-125	KLS-R100	A6K-100R
5052	KTS-R125	2028220-125	KLS-R125	A6K-125R
5062	KTS-R150	2028220-160	KLS-R150	A6K-150R
5072	FWH-220	2028220-200	L50S-225	A50-P225
5102	FWH-250	2028220-250	L50S-250	A50-P250

KTS-fuses from Bussmann may substitute KTN for 240 V drives.

FWH-fuses from Bussmann may substitute FWX for 240 V drives.

KLSR fuses from LITTEL FUSE may substitute KLNR fuses for 240 V drives.

L50S fuses from LITTEL FUSE may substitute L50S fuses for 240 V drives.

A6KR fuses from FERRAZ SHAWMUT may substitute A2KR for 240 V drives.

A50X fuses from FERRAZ SHAWMUT may substitute A25X for 240 V drives.

**Non UL compliance**

If UL/cUL is not to be complied with, we recommend the above mentioned fuses or:

### ■ Mechanical dimensions

All the below listed measurements are in mm.

	A	B	C	D	a	b	ab/be	Type
Compact IP 20								
5001 - 5003 200 - 240 V	395	220	160		384	200	100	C
5001 - 5005 380 - 500 V								
5004 - 5006 200 - 240 V	395	220	200		384	200	100	C
5006 - 5011 380 - 500 V								
5008 200 - 240 V	560	242	260		540	200	200	D
5016 - 5022 380 - 500 V								
5011 - 5016 200 - 240 V	700	242	260		680	200	200	D
5027 - 5032 380 - 500 V								
5022 - 5027 200 - 240 V	800	308	296		780	270	200	D
5042 - 5062 380 - 500 V								
Compact IP 54								
5001 - 5003 200 - 240 V	460	282	195	85	260	258	100	F
5001 - 5005 380 - 500 V								
5004 - 5006 200 - 240 V	530	282	195	85	330	258	100	F
5006 - 5011 380 - 500 V								
5008 - 5011 200 - 240 V	810	350	280	70	560	326	200	F
5016 - 5027 380 - 500 V								
5016 - 5027 200 - 240 V								
5032 - 5062 380 - 500 V	940	400	280	70	690	375	200	F
5072 - 5102 380 - 500 V	800	370	335		780	330	225	D

ab: Minimum space above enclosure

be: Minimum space below enclosure

1: Only above enclosure (ab) IP 00 when built in a Rittal cabinet.

### ■ Mechanical dimensions, cont.

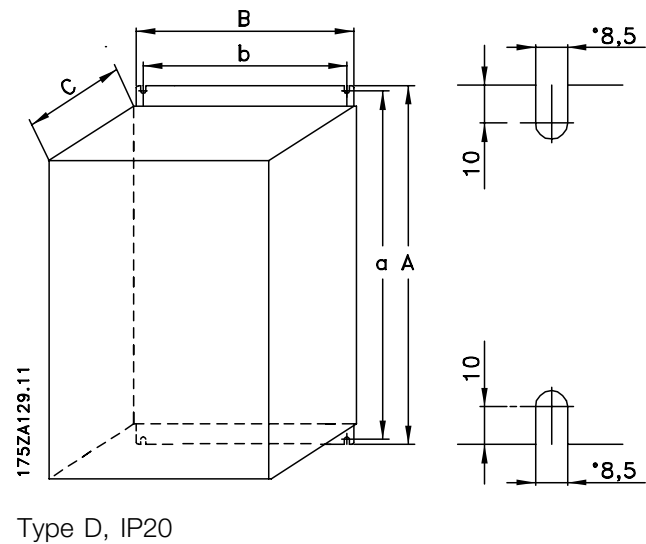
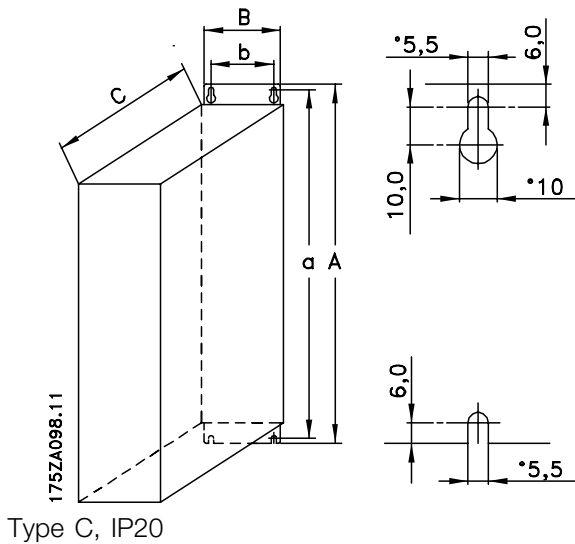

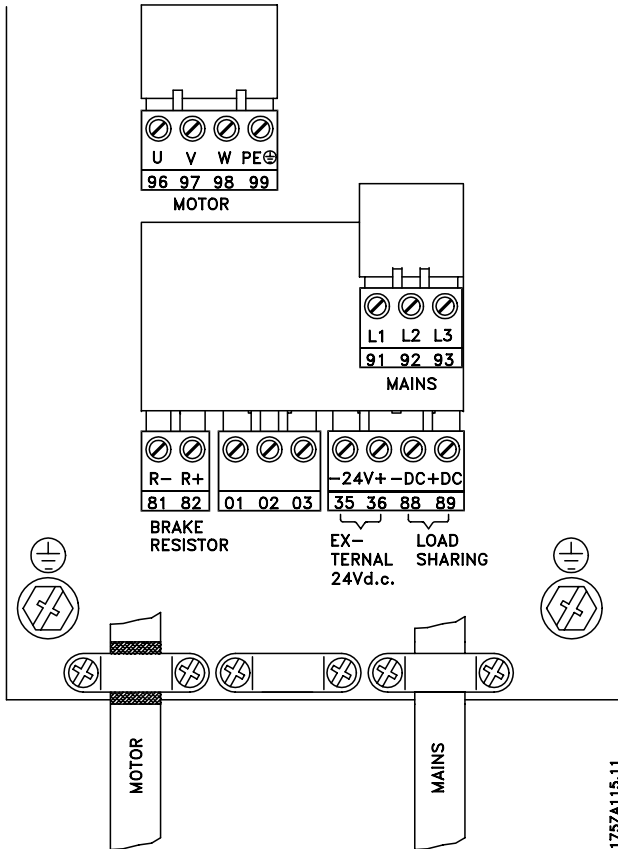

175ZA115.11

Compact IP 20 / IP 54  
 AKD 5001-5006 200-240 V  
 AKD 5001-5011 380-500 V

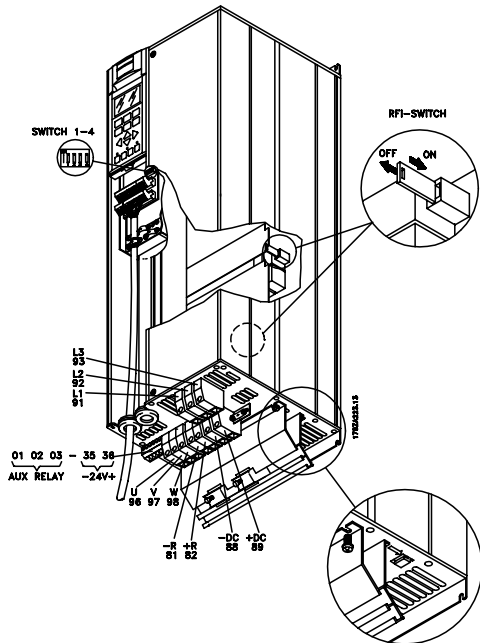

Compact IP 20  
 AKD 5008-5027 200-240 V  
 AKD 5016-5062 380-500 V

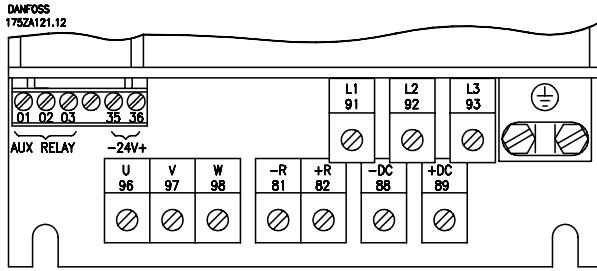

**Compact IP 20**  
AKD 5008-5027 200-240 V  
AKD 5016-5062 380-500 V

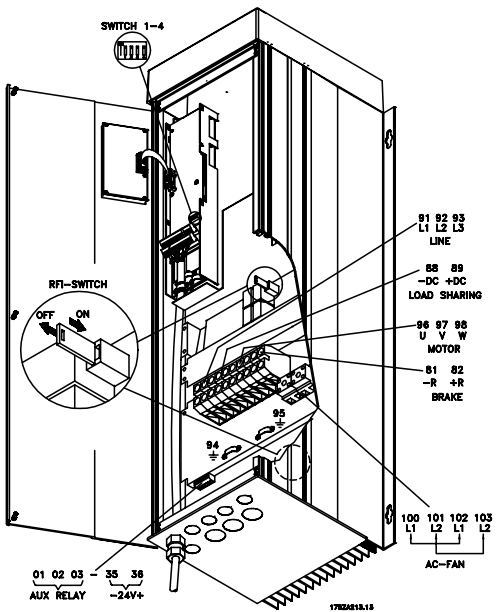

**Compact IP 54**  
AKD 5008-5027 200-240 V  
AKD 5016-5062 380-500 V

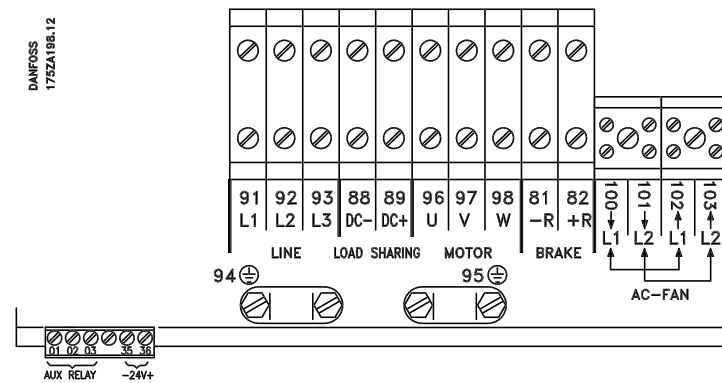

**Compact IP 54**  
AKD 5008-5027 200-240 V  
AKD 5016-5062 380-500 V

